

SUBMITTAL DATA

GUD48W2/D-D(U) & GUD48AH2/D-D(U)
48000 BTU/H Single Zone Split AHU & Heat Pump System

Job Name <input type="text"/>	Location <input type="text"/>	Date <input type="text"/>
Purchaser <input type="text"/>	Engineer <input type="text"/>	
Submitted to <input type="text"/>	For <input type="text"/>	
Unit Designation <input type="text"/>	Schedule No. <input type="text"/>	

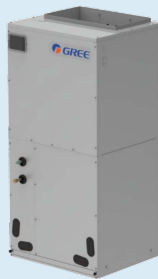

GUD48AH2/D-D(U)



GUD48W2/D-D(U)

GENERAL FEATURES

- AHRI Certificate: [210421036](#)
- High Efficiency DC Inverter Technology
- 24VAC Thermostat Compatible
- Zero Lot Line Design
- 8 Speed Fan Motor
- Matched with GREE Indoor Unit
- Designed for New Construction or Replacement Market
- Compact and Quiet, as low as 63 dB(A) Side Discharge Outdoor Unit
- Cooling and Heating down to -15°C (5°F)
- Coil (Outdoor) Copper Tube/Aluminum Fin with Anti-Corrosion Coil Coating (Gold Colored Fin - 1500Hr Salt Spray Rating)
- Coil (Indoor) Copper Tube/Aluminum Fin with Anti-Corrosion Coil Coating (Blue Colored Fin - 500Hr Salt Spray Rating)

SPECIFICATIONS, FEATURES & FUNCTION SUMMARY

SPECIFICATIONS		GUD48W2/D-D(U) & GUD48AH2/D-D(U)		FEATURES & FUNCTIONS SUMMARY		GUD48W2/D-D(U) & GUD48AH2/D-D(U)	
System Type		HEAT PUMP					
SYSTEM PERFORMANCE							
Cooling	Min - Max	Btu/h	34760 - 46000				
	Capacity @95°F	Btu/h	46000				
Heating	Min - Max	Btu/h	22270 - 50000				
	Capacity @5°F	Btu/h	26200				
	Capacity @17°F	Btu/h	26000				
	Capacity @47°F	Btu/h	46000				
SEER2		15					
EER2		8.6					
HSPF2		7.7					
COP @5°F		1.8					
COP @47°F		2.7					
Cooling Temperature Range		°F	5 - 118				
Heating Temperature Range		°F	5 - 75				
Refrigerant Type		R410A					
INDOOR UNIT							
Power Supply		VAC	208-230V / 1Ph / 60 Hz				
Sound Pressure Level		dB(A)	53				
Control Voltage		VAC	24				
Rated Current Cooling		A	5				
Rated Current Heating		A	5				
MCA		A	6.9				
MOCP		A	15				
Electric Heater (Optional)		kW	5, 8, 10, 15, 20				
Air Flow		CFM	1400				
External Static Pressure (Up to)		In W.c.	1.0				
Dehumidification		pt/hr	12.13				
External Dimensions (W x H x D)		in	24-3/4 x 52 x 21-1/4				
Package Dimension (W x H x D)		in	27-5/16 x 54-1/4 x 26				
Net Weight		lbs	189.6				
Gross Weight		lbs	203.9				
OUTDOOR UNIT							
Power Supply		VAC	208-230V / 1Ph / 60 Hz				
Sound Pressure Level		dB(A)	63				
Control Voltage		VAC	24				
Rated Current Cooling		A	29				
Rated Current Heating		A	29				
MCA		A	36.5				
MOCP		A	60				
External Dimensions (W x H x D)		in	37-1/8 x 32-1/2 x 14-5/8				
Package Dimension (W x H x D)		in	43 x 34-7/8 x 19-5/8				
Net Weight		lbs	164.2				
Gross Weight		lbs	175.3				
Refrigerant Charge - R410A		oz	158.7				
Additional Charge		oz/ft	0.32				
REFRIGERANT PIPING							
Line Set Size (Liquid - Gas) - Flared Connections		in	3/8 - 3/4				
Pre-Charge Length		ft	31				
Pipe Length (Min - Max)		ft	10 - 164				
Max. Pipe Elevation		ft	98.4				
SYSTEM FEATURES							
Compressor		Inverter					
Ultra Low Frequency Torque Control		Yes					
Power Factor Correction		Yes					
Compressor Type		Rotary					
Refrigerant Type		R410A					
Outdoor Electronic Expansion Valve (EEV)		Yes					
Indoor TXV Control		Yes					
Basepan With Electric Heater		Yes					
Compressor With Electric Heater		Yes					
Fin Coating (Outdoor - Golden & Indoor - Blue)		Acrylic Resin					
Intelligent Defrosting		Yes					
Intelligent Preheating		Yes					
Low Voltage Startup		Yes					
Memory/Power Failure Recovery		Yes					
Self Diagnosis		Yes					
Low Ambient Cooling		No					
24VAC Thermostat Compatible		Yes					
Indoor Fan Type		Centrifugal					
Multi Fan Speeds		8					
Auxiliary Electrical Heater		Optional					

FAN PERFORMANCE

Static Pressure (Inches W.C.)	0	0.1	0.15	0.2	0.3	0.4	0.5	0.6	0.7	0.8	0.9	1
Speed 1 (CFM)	1640	1500										
Speed 2 (CFM)	1680	1560	1500									
Speed 3 (CFM)	1810	1690	1620	1550								
Speed 4 (CFM)	1930	1830	1770	1710	1580	1480						
Speed 5 (CFM)	2200	2110	2040	1980	1860	1720	1620	1490				
Speed 6 (CFM)	2240	2190	2145	2100	2010	1870	1750	1615	1500			
Speed 7 (CFM)	2280	2240	2200	2180	2130	2080	2000	1880	1750	1600		
Speed 8 (CFM)	2300	2260	2220	2190	2140	2090	2040	1980	1930	1800	1700	1550

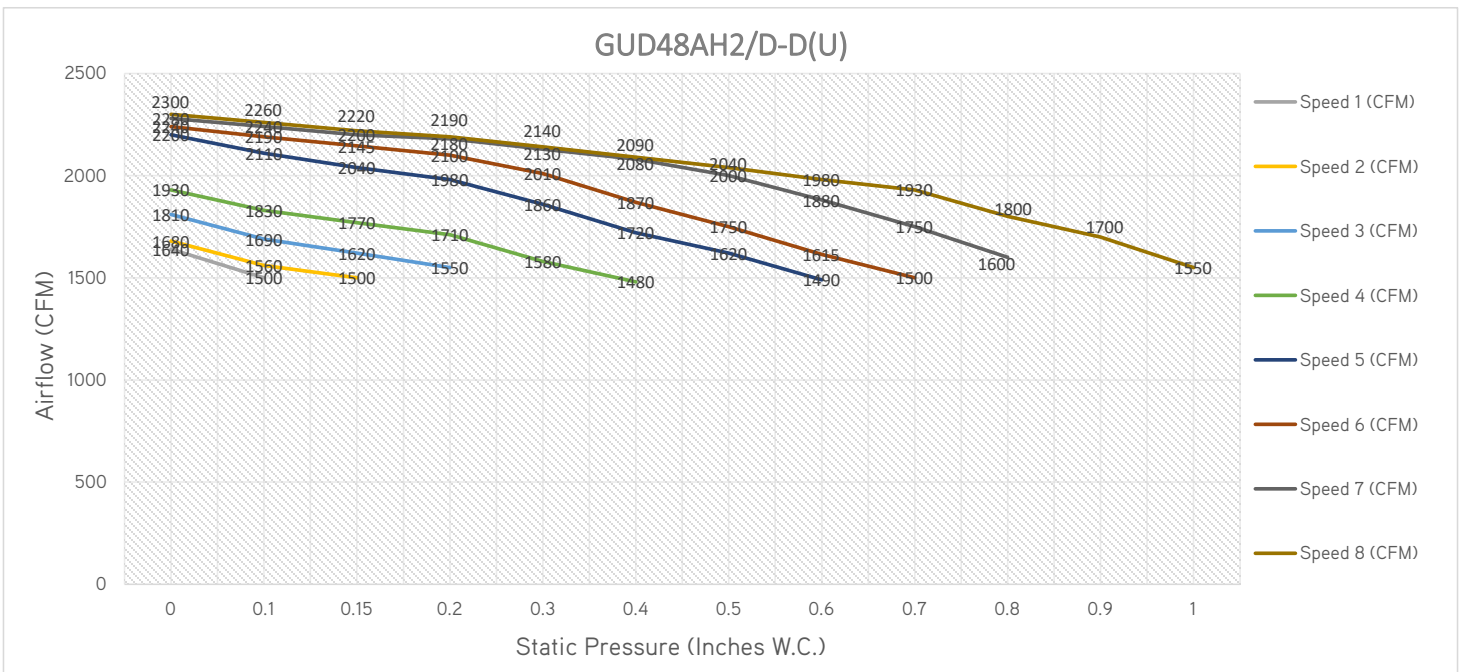

NOTE:

1. Above chart CFM ratings are based on dry coil with factory filter installed.
2. For wet coil CFM ratings, multiply the CFM by 0.96 correction factor.

DIMENSIONS

INDOOR UNIT

Unit: inch

GUD48AH2/D-D(U)	
DIMENSIONS	
A	11-5/8
B	20
H	52
W	24-3/4
D	21-1/4

FILTER SIZE	
Supplied*	20-3/4 x 20-3/8 x 5/8
Suggested	20-3/4 x 20-3/8 x 1

*Supplied filter is metal mesh

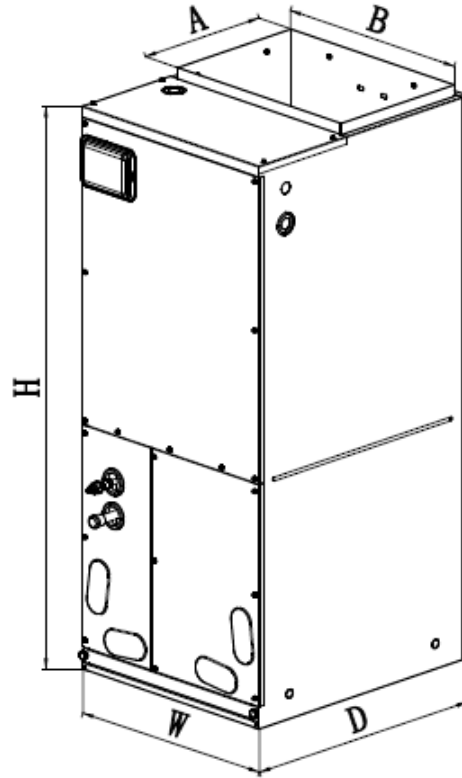

OUTDOOR UNIT

Unit: inch

GUD48W2/D-D(U)	
DIMENSIONS	
A	37-1/8
B	15-13/16
C	32-1/2
D	22-7/16
E	14-9/16
F	38-1/4
G	14-5/8

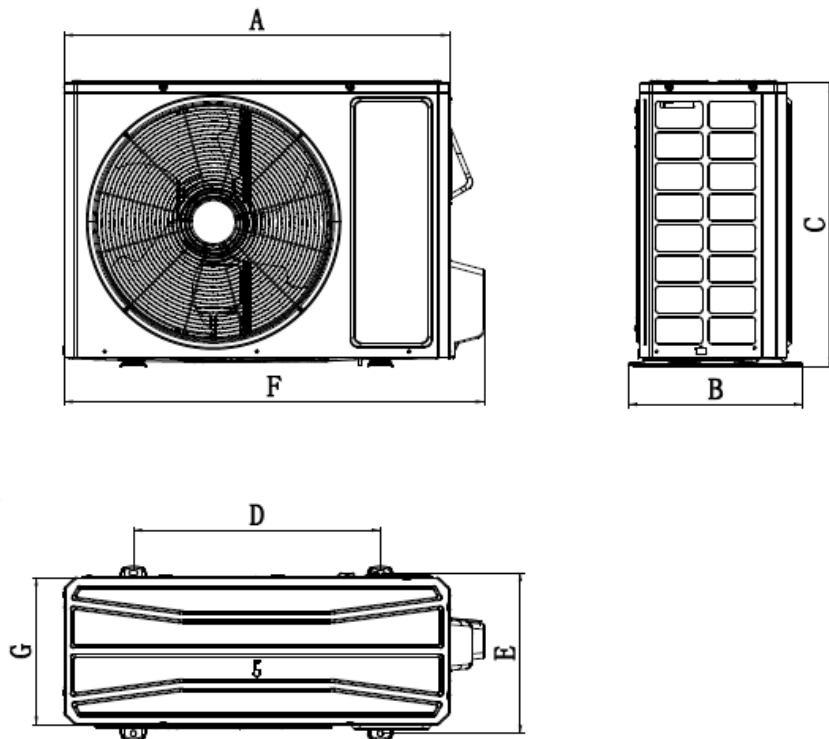

ACCESSORY HEATER AND GENERAL INFORMATION

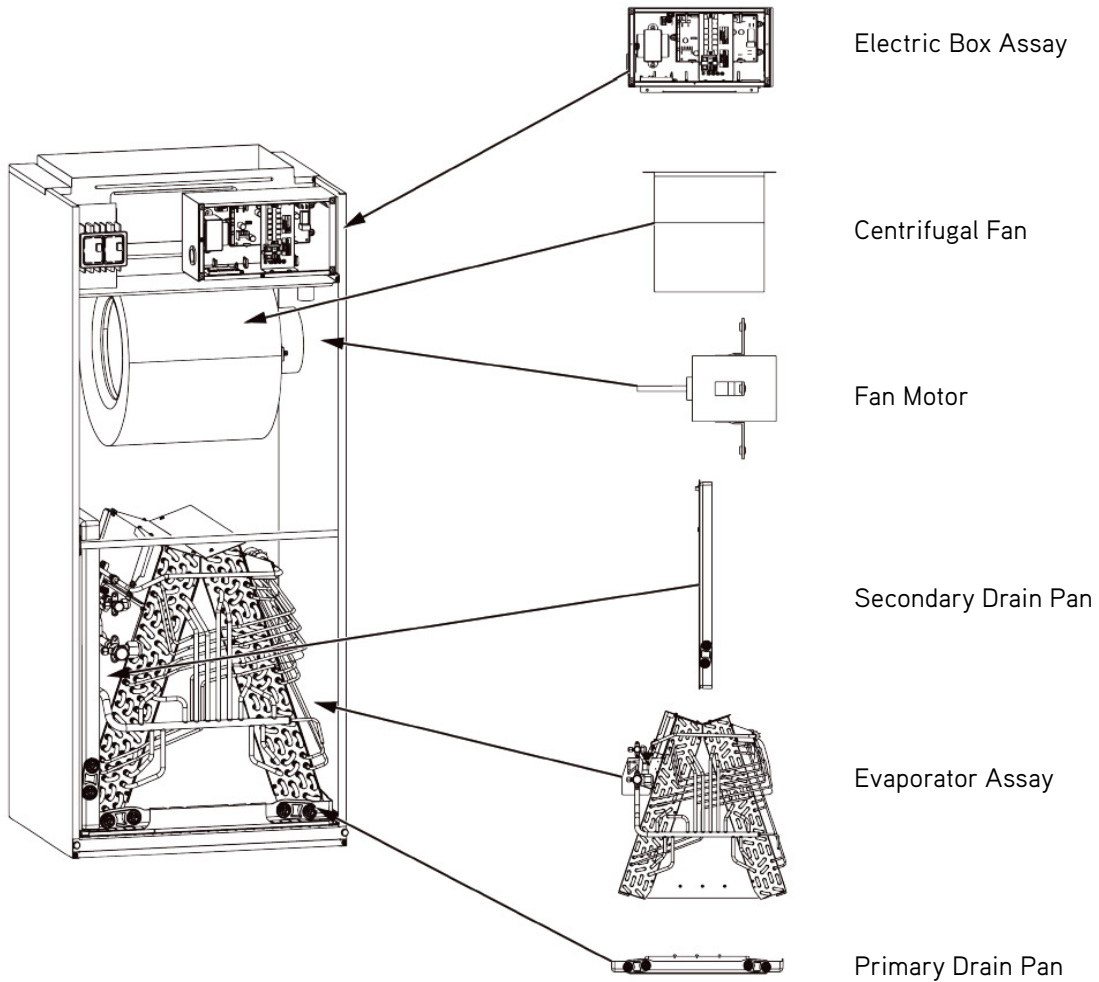

Model	Heat Kit Model	Electric Heat (kW)		Min. Circuit Ampacity (A)		Max Fuse or Breaker (A)								
		208V	230V	208V	230V	208V	230V							
GUD48AH2/D-D(U)	One Mains Supply													
	ELEMHT16-5KW	3.74	4.6	31	33	35	35							
	ELEMHT16-8KW	6.03	7.36	44	48	45	50							
	ELEMHT16-10KW	7.49	9.2	53	58	60	60							
	Two Mains Supply													
			Power A	Power B	Power A	Power B	Power A	Power B	Power A	Power B	Power A	Power B	Power A	Power B
	ELEMHT16-15KW	7.49	3.74	9.2	4.6	53	23	58	25	60	25	60	30	30
ELEMHT16-20KW	7.49	7.49	9.2	9.2	53	46	58	50	60	50	60	60	60	

CLEARANCES

INDOOR UNIT

Minimum clearance

FRONT > 24

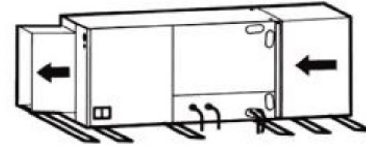
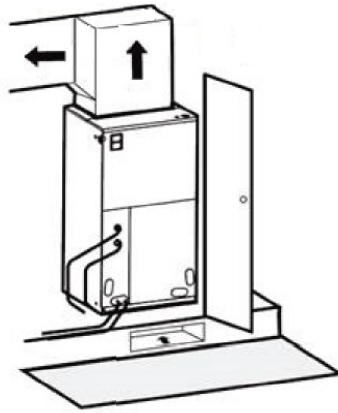

Horizontal Left Configuration - No Modification Needed

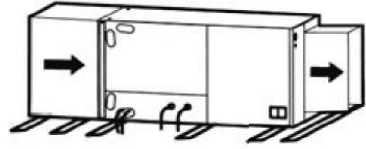

Horizontal Right Configuration - Must Relocate Drain Pan

NOTE:

Allow a minimum of 24" in front of the unit for service clearance. When installing in an area directly over a finished ceiling (such as an attic), an emergency drain pan is required directly under the unit. **See local and state codes for requirements.** When installing this unit in an area that may become wet, elevate the unit with a sturdy, non-porous material. In installations that may lead to physical damage (i.e. a garage) it is advised to install a protective barrier to prevent such damage. This air handler is designed for a complete supply and return ductwork system.

OUTDOOR UNIT

Minimum clearance

NOTE:

Install the Outdoor Unit **2 Inches** Above the Expected Snow Line

1. When one outdoor unit is to be installed.

A - E	H_b H_d H		(in)				
			a	b	c	d	e
B	-	-	-	≥ 4	-	-	-
A, B, C	-	-	≥ 12	≥ 4	≥ 4	-	-
B, E	-	-	-	≥ 4	-	-	≥ 40
A, B, C, E	-	-	≥ 12	≥ 6	≥ 6	-	≥ 40
D	-	-	-	-	-	≥ 40	-
D, E	-	-	-	-	-	≥ 40	≥ 40
B, D	$H_b < H_d$	$H_d < H$	-	≥ 4	-	≥ 40	-
	$H_b > H_d$	$H_d > H$	-	≥ 4	-	≥ 40	-
B, D, E	$H_b < H_d$	$H_b \leq 1/2H$	-	≥ 10	-	≥ 80	≥ 40
		$1/2H < H_b \leq H$	-	≥ 10	-	≥ 80	≥ 40
	$H_b > H_d$	$H_b > H$	Prohibited				
		$H_b \leq 1/2H$	-	≥ 4	-	≥ 80	≥ 40
		$1/2H < H_b \leq H$	-	≥ 8	-	≥ 80	≥ 40
	$H_b > H$	Prohibited					

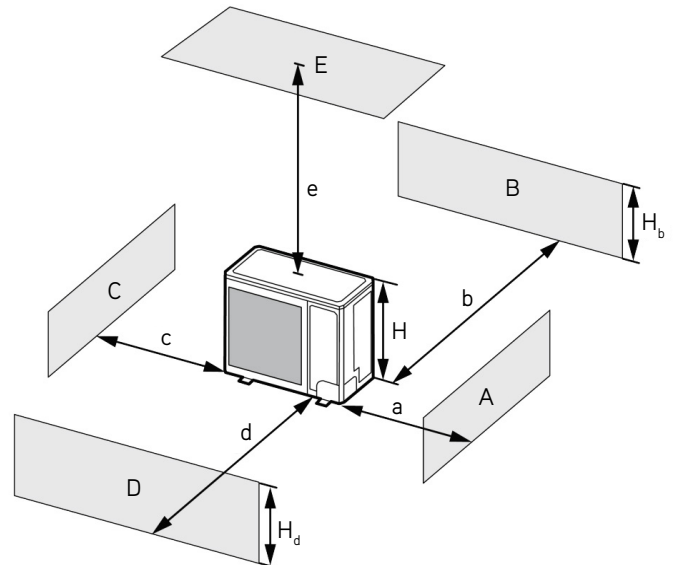

CLEARANCES

2. When two or more outdoor units are to be installed side by side.

A - E	H_b H_d H	(in)					
		a	b	c	d	e	
A, B, C	-	≥ 12	≥ 12	≥ 40	-	-	
A, B, C, E	-	≥ 12	≥ 12	≥ 40	-	≥ 40	
D	-	-	-	-	≥ 80	-	
D, E	-	-	-	-	≥ 80	≥ 40	
B, D	$H_b < H_d$	-	≥ 12	-	≥ 80	-	
	$H_d > H$	-	≥ 10	-	≥ 80	-	
B, D, E	$H_b > H_d$	$H_d \leq 1/2H$	-	≥ 10	-	≥ 80	
		$1/2H < H_d \leq H$	-	≥ 12	-	≥ 100	
	$H_b < H_d$	$H_d \leq 1/2H$	-	≥ 12	-	≥ 80	≥ 40
		$1/2H < H_d \leq H$	-	≥ 12	-	≥ 100	≥ 40
B, D, E	$H_b > H_d$	$H_b > H$	Prohibited				
		$H_d \leq 1/2H$	-	≥ 10	-	≥ 100	≥ 40
	$H_d > H$	$1/2H < H_d \leq H$	-	≥ 12	-	≥ 100	≥ 40
	$H_b > H_d$	$H_d > H$	Prohibited				

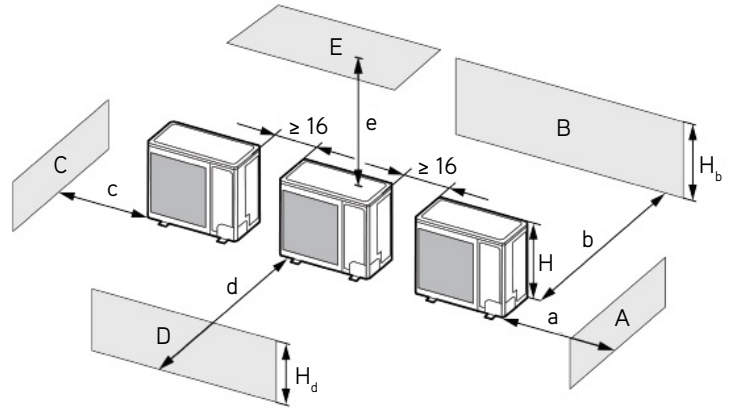

3. When outdoor units are installed in rows.

H_b H_d	(in)
$H_b \leq 1/2H$	$b \leq 10$
$1/2H < H_b \leq H$	$b \leq 12$
$H_b > H_d$	Prohibited

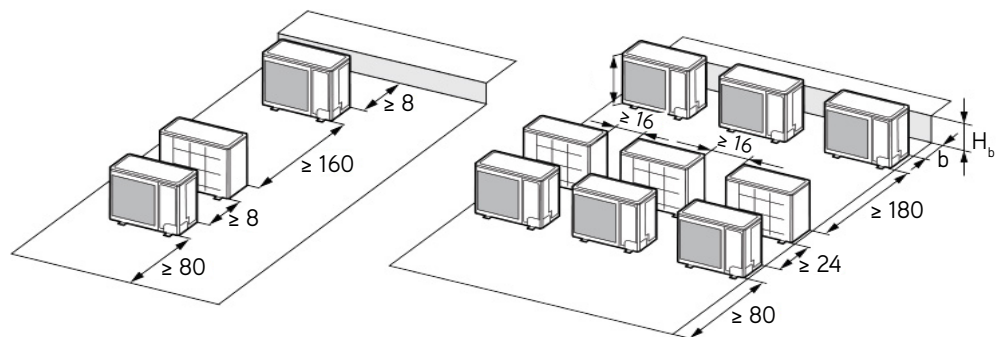

4. When outdoor units are installed one above another.

