

## SUBMITTAL DATA

GUD24AH2/D-D(U) & GUD24W2/D-D(U)  
24000 BTU/H Unitary Heat Pump Split System

Job Name

Location

Date

Purchaser

Engineer

Submitted to

For

Unit Designation

Schedule No.



GUD24AH2/D-D(U)



GUD24W2/D-D(U)

### GENERAL FEATURES

- AHRI Certificate: [210421032](#)
- High Efficiency DC Inverter Technology
- 24VAC Thermostat Compatible
- Zero Lot Line Design
- 8 Speed Fan Motor
- Matched with GREE Indoor Unit
- Designed for New Construction or Replacement Market
- Compact and Quiet, as low as 56 dB(A) Side Discharge Outdoor Unit
- Cooling and Heating down to -15°C (5°F)
- Coil (Outdoor) Copper Tube/Aluminum Fin with Anti-Corrosion Coil Coating (Gold Colored Fin - 1500Hr Salt Spray Rating)
- Coil (Indoor) Copper Tube/Aluminum Fin with Anti-Corrosion Coil Coating (Blue Colored Fin - 500Hr Salt Spray Rating)

## SPECIFICATIONS, FEATURES & FUNCTION SUMMARY

SPECIFICATIONS		GUD24AH2/D-D(U) & GUD24W2/D-D(U)		FEATURES & FUNCTIONS SUMMARY		GUD24AH2/D-D(U) & GUD24W2/D-D(U)	
System Type		HEAT PUMP					
<b>SYSTEM PERFORMANCE</b>				<b>SYSTEM FEATURES</b>			
Cooling	Min - Max	Btu/h	16100 - 25000	Compressor	Inverter		
	Capacity @95°F	Btu/h	23000	Ultra Low Frequency Torque Control	Yes		
Heating	Min - Max	Btu/h	11135 - 27000	Power Factor Correction	Yes		
	Capacity @5°F	Btu/h	13100	Compressor Type	Rotary		
	Capacity @17°F	Btu/h	14600	Refrigerant Type	R410A		
	Capacity @47°F	Btu/h	23000	Outdoor Electronic Expansion Valve (EEV)	Yes		
SEER2			15.5	Indoor TXV Control	Yes		
EER2			10.5	Basepan With Electric Heater	Yes		
HSPF2			7.8	Compressor With Electric Heater	Yes		
COP @5°F			1.8	Fin Coating (Outdoor - Golden & Indoor - Blue)	Acrylic Resin		
COP @47°F			3.1	Intelligent Defrosting	Yes		
Cooling Temperature Range	°F	5 - 118		Intelligent Preheating	Yes		
Heating Temperature Range	°F	5 - 75		Low Voltage Startup	Yes		
Refrigerant Type	R410A			Memory/Power Failure Recovery	Yes		
<b>INDOOR UNIT</b>		<b>GUD24AH2/D-D(U)</b>		Self Diagnosis	Yes		
Power Supply	VAC	208-230V / 1Ph / 60 Hz		Low Ambient Cooling	No		
Sound Pressure Level	dB(A)	47		24VAC Thermostat Compatible	Yes		
Control Voltage	VAC	24		Indoor Fan Type	Centrifugal		
Rated Current Cooling	A	3		Multi Fan Speeds	8		
Rated Current Heating	A	3		Auxiliary Electrical Heater	Optional		
MCA	A	3.5					
MOCP	A	15					
Electric Heater (Optional)	kW	5, 8					
Air Flow	CFM	800					
External Static Pressure (Up to)	In W.c.	1.0					
Dehumidification	pt/hr	3.06					
External Dimensions (W x H x D)	in	18-1/8 x 43-1/2 x 21-1/4					
Package Dimension (W x H x D)	in	20-5/8 x 45-11/16 x 26					
Net Weight	lbs	125.7					
Gross Weight	lbs	134.5					
<b>OUTDOOR UNIT</b>		<b>GUD24W2/D-D(U)</b>					
Power Supply	VAC	208-230V / 1Ph / 60 Hz					
Sound Pressure Level	dB(A)	56					
Control Voltage	VAC	24					
Rated Current Cooling	A	15.5					
Rated Current Heating	A	15.5					
MCA	A	19.5					
MOCP	A	30					
External Dimensions (W x H x D)	in	35 x 25-7/8 x 13-3/8					
Package Dimension (W x H x D)	in	40-5/8 x 28-3/4 x 18					
Net Weight	lbs	99.2					
Gross Weight	lbs	108					
Refrigerant Charge - R410A	oz	70.6					
Additional Charge	oz/ft	0.32					
<b>REFRIGERANT PIPING</b>							
Line Set Size (Liquid - Gas) - Flared Connections	in	3/8 - 3/4					
Pre-Charge Length	ft	31					
Pipe Length (Min - Max)	ft	10 - 98.4					
Max. Pipe Elevation	ft	49.2					

## FAN PERFORMANCE

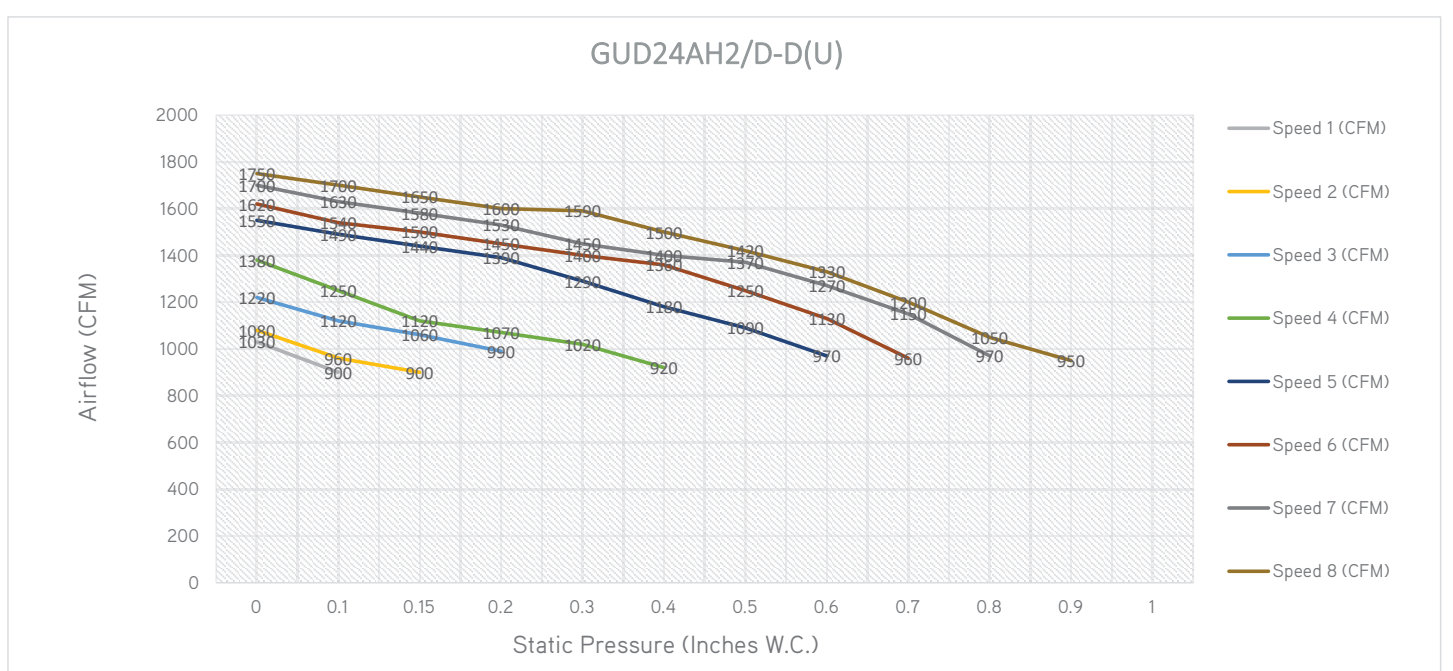

Static Pressure (Inches W.C.)	0	0.1	0.15	0.2	0.3	0.4	0.5	0.6	0.7	0.8	0.9	1
Speed 1 (CFM)	1030	900										
Speed 2 (CFM)	1080	960	900									
Speed 3 (CFM)	1220	1120	1060	990								
Speed 4 (CFM)	1380	1250	1120	1070	1020	920						
Speed 5 (CFM)	1550	1490	1440	1390	1290	1180	1090	970				
Speed 6 (CFM)	1620	1540	1500	1450	1400	1360	1250	1130	960			
Speed 7 (CFM)	1700	1630	1580	1530	1450	1400	1370	1270	1150	970		
Speed 8 (CFM)	1750	1700	1650	1600	1590	1500	1420	1330	1200	1050	950	

### NOTE:

1. Above chart CFM ratings are based on dry coil with factory filter installed.
2. For wet coil CFM ratings, multiply the CFM by 0.96 correction factor.

## DIMENSIONS

### INDOOR UNIT

Unit: inch

GUD24AH2/D-D(U)	
DIMENSIONS	
A	11-5/8"
B	16-3/4"
H	43-1/2"
W	18-1/8"
D	21-1/4"

FILTER SIZE	
Supplied*	16-1/2 x 20-3/8 x 5/8
Suggested	16-1/2 x 20-3/8 x 1

\*Supplied filter is metal mesh

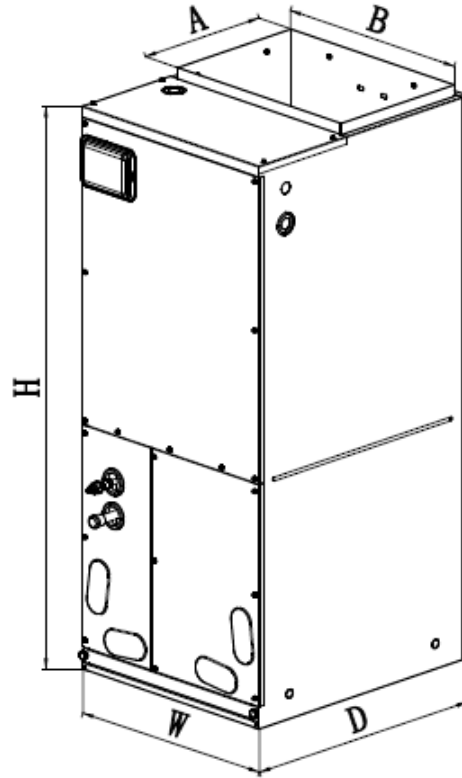

### OUTDOOR UNIT

Unit: inch

GUD24W2/D-D(U)	
DIMENSIONS	
A	35
B	15-13/16
C	25-7/8
D	22-7/16
E	14-9/16
F	38-1/4
G	13-3/8

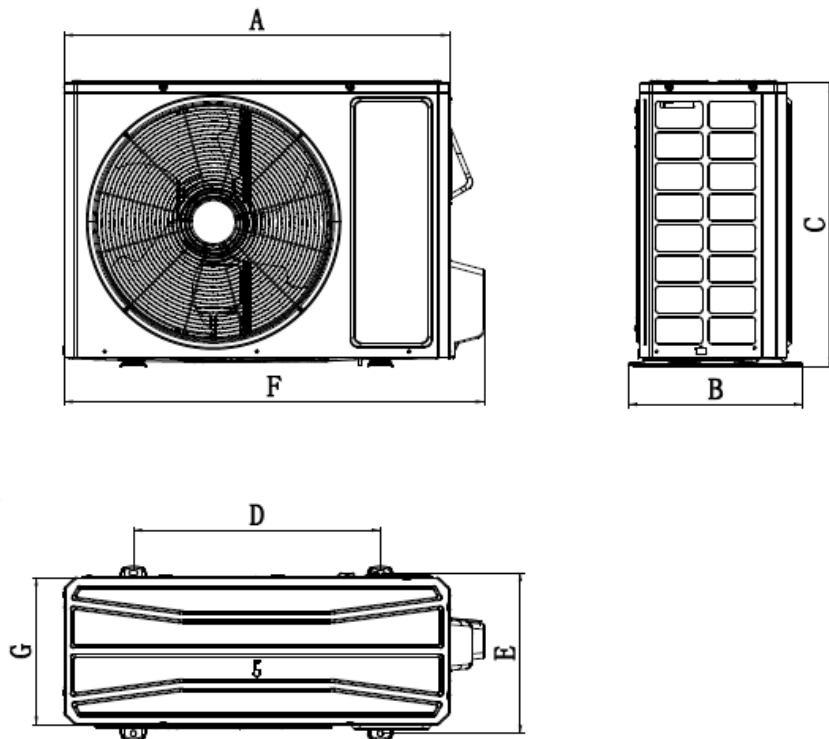

## ACCESSORY HEATER AND GENERAL INFORMATION

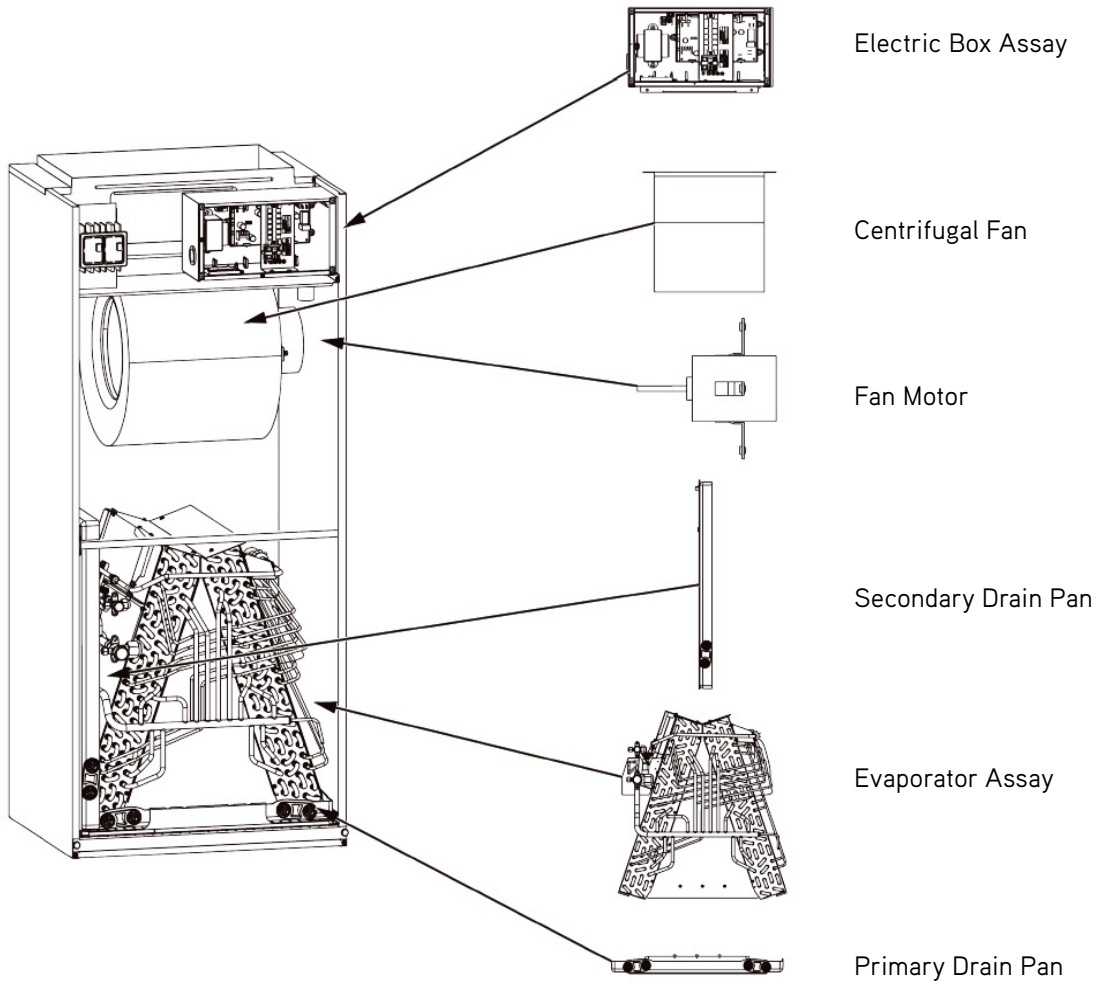

Model	Heat Kit Model	Electric Heat (kW)		Min. Circuit Ampacity (A)		Max Fuse or Breaker (A)	
		208V	230V	208V	230V	208V	230V
<b>GUD24AH2/D-D(U)</b>	ELEMHT16-5KW	3.74	4.6	31	33	35	35
	ELEMHT16-8KW	6.03	7.36	44	48	45	50

# CLEARANCES

## INDOOR UNIT

Minimum clearance

FRONT > 24

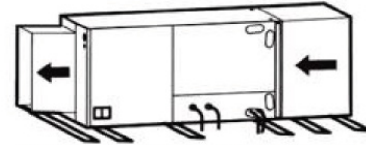
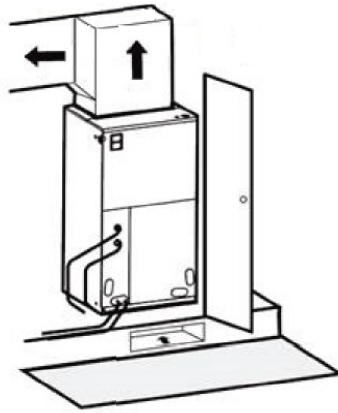

Horizontal Left Configuration - No Modification Needed

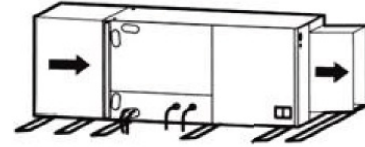

Horizontal Right Configuration - Must Relocate Drain Pan

### NOTE:

Allow a minimum of 24" in front of the unit for service clearance. When installing in an area directly over a finished ceiling (such as an attic), an emergency drain pan is required directly under the unit. **See local and state codes for requirements.** When installing this unit in an area that may become wet, elevate the unit with a sturdy, non-porous material. In installations that may lead to physical damage (i.e. a garage) it is advised to install a protective barrier to prevent such damage. This air handler is designed for a complete supply and return ductwork system.

## OUTDOOR UNIT

Minimum clearance

### NOTE:

Install the Outdoor Unit **2 Inches** Above the Expected Snow Line

1. When one outdoor unit is to be installed.

A - E	$H_b$ $H_d$ H		(in)				
			a	b	c	d	e
B	-	-	-	≥ 4	-	-	-
A, B, C	-	-	≥ 12	≥ 4	≥ 4	-	-
B, E	-	-	-	≥ 4	-	-	≥ 40
A, B, C, E	-	-	≥ 12	≥ 6	≥ 6	-	≥ 40
D	-	-	-	-	-	≥ 40	-
D, E	-	-	-	-	-	≥ 40	≥ 40
B, D	$H_b < H_d$	$H_d < H$	-	≥ 4	-	≥ 40	-
	$H_b > H_d$	$H_d > H$	-	≥ 4	-	≥ 40	-
B, D, E	$H_b < H_d$	$H_b \leq 1/2H$	-	≥ 10	-	≥ 80	≥ 40
		$1/2H < H_b \leq H$	-	≥ 10	-	≥ 80	≥ 40
	$H_b > H_d$	$H_b > H$	Prohibited				
		$H_b \leq 1/2H$	-	≥ 4	-	≥ 80	≥ 40
		$1/2H < H_b \leq H$	-	≥ 8	-	≥ 80	≥ 40
	$H_b > H$	Prohibited					

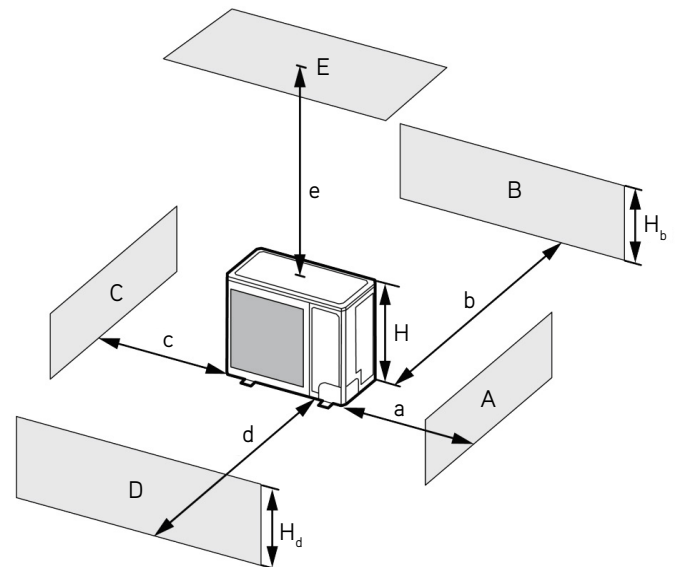

# CLEARANCES

2. When two or more outdoor units are to be installed side by side.

A - E	$H_b$ $H_d$ $H$		(in)				
			a	b	c	d	e
A, B, C	-	-	$\geq 12$	$\geq 12$	$\geq 40$	-	-
A, B, C, E	-	-	$\geq 12$	$\geq 12$	$\geq 40$	-	$\geq 40$
D	-	-	-	-	-	$\geq 80$	-
D, E	-	-	-	-	-	$\geq 80$	$\geq 40$
B, D	$H_b < H_d$	$H_d > H$	-	$\geq 12$	-	$\geq 80$	-
	$H_b > H_d$	$H_d \leq 1/2H$	-	$\geq 10$	-	$\geq 80$	-
B, D, E	$H_b > H_d$	$1/2H < H_d \leq H$	-	$\geq 12$	-	$\geq 100$	$\geq 40$
		$H_b \leq 1/2H$	-	$\geq 12$	-	$\geq 80$	$\geq 40$
	$H_b < H_d$	$1/2H < H_b \leq H$	-	$\geq 12$	-	$\geq 100$	$\geq 40$
		$H_b > H$	Prohibited				
	$H_b > H_d$	$H_d \leq 1/2H$	-	$\geq 10$	-	$\geq 100$	$\geq 40$
		$1/2H < H_d \leq H$	-	$\geq 12$	-	$\geq 100$	$\geq 40$
	$H_d > H$	Prohibited					

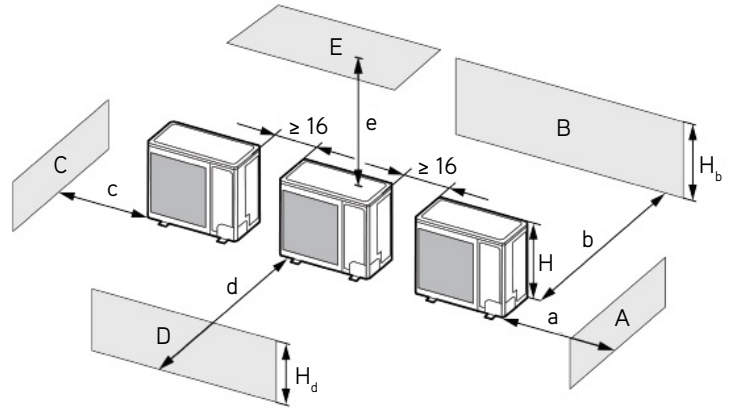

3. When outdoor units are installed in rows.

$H_b$ $H_d$	(in)
$H_b \leq 1/2H$	$b \leq 10$
$1/2H < H_b \leq H$	$b \leq 12$
$H_b > H_d$	Prohibited

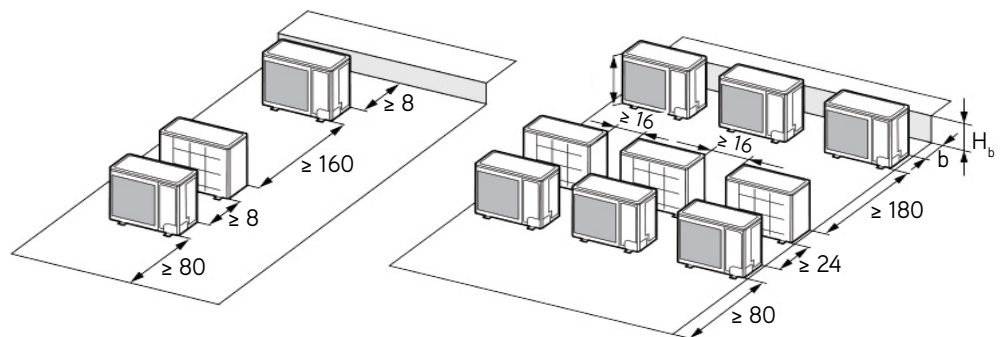

4. When outdoor units are installed one above another.

